

## CASE STUDY – Conical Tank Covers

### PRIMARY TASKS

- Assessment of a number of design proposals
- Concept through to production
- Finite Element Analysis
- Tooling design for a range of sizes
- Laminate drawings for series production
- Ongoing engineering support

Argo Engineering Solutions was contracted by Corporate Engineering Ltd to provide design and engineering support for a new range of self-supporting conical tank covers. The scope of work included taking the covers from initial design through to production with emphasis on variation in size, ease of assembly, transport to site and customisation. The client brief required Argo Engineering to investigate a number different design options and select one to take through to final production for two sizes

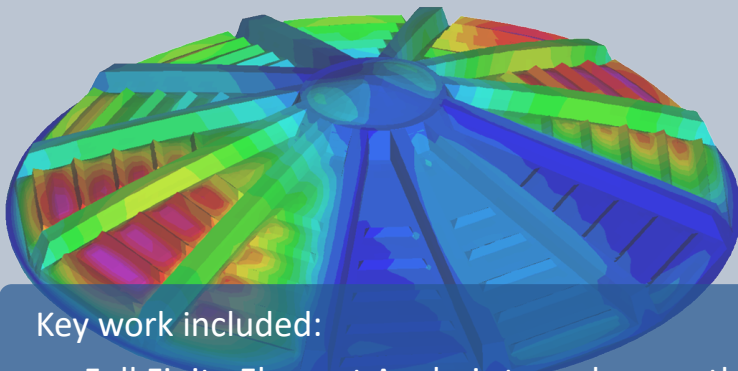

In order for the project to be successful, a close working relationship with Corporate Engineering was required during all key stages of delivery

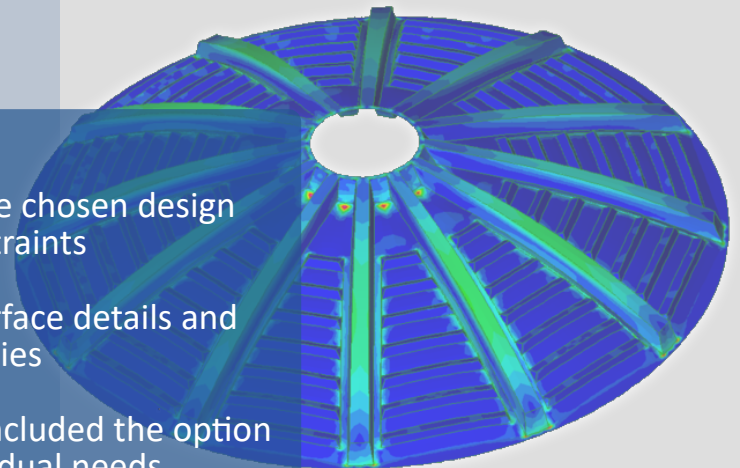

#### Key work included:

- Full Finite Element Analysis to make sure the chosen design satisfied structural and environmental constraints
- Development of mould tools, standard interface details and fittings for both the small and large assemblies
- Supply of production drawings which also included the option of customisation to suit the end users individual needs



With the Conical Covers now in full production, Argo Engineering Solutions continues to provide support as and when required